

WALL MOUNTING INSTRUCTIONS

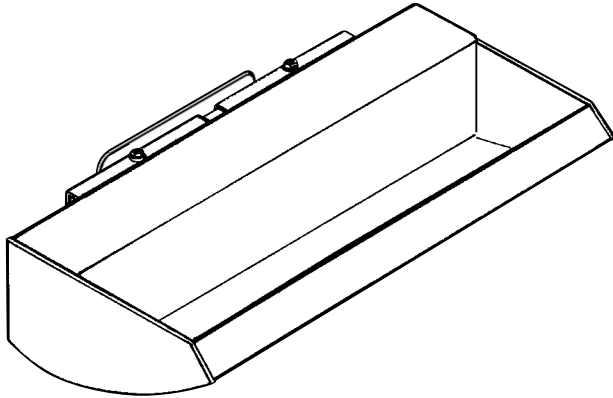

PLEASE READ ALL INSTRUCTIONS BEFORE BEGINNING INSTALLATION.

Fixtures are designated "Feeder" or "Joiner". The "feeder" is the electrical feed unit and is used to supply power to a continuous row or is also used when installing a single fixture. "Joiner" fixtures connect in line after the feeder. If installing in rows, we recommend placing the power feed fixture at either end of the row for easiest connection to joiner fixtures.

POWER FEED SUGGESTIONS

For best appearance and easiest fixture installation, mount the J-box HORIZONTALLY.

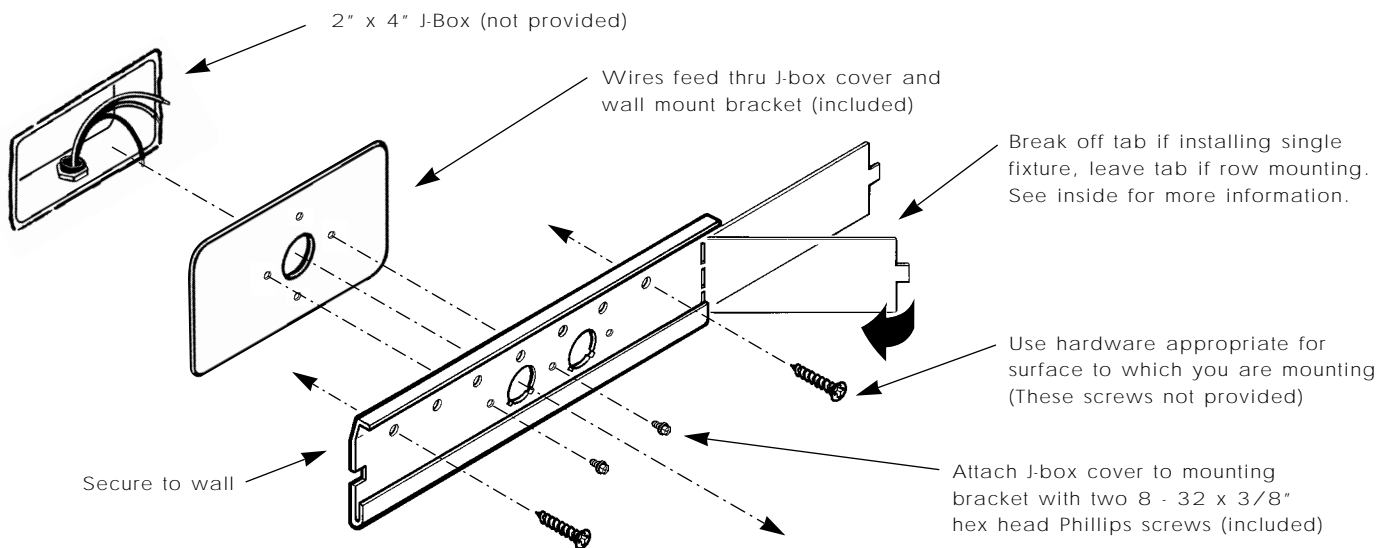

1. PLAN THE INSTALLATION

Determine the number & sizes of fixtures to be installed and their power feed requirements.

With J-box cover attached, level and secure bracket to wall. Position so that J-box cover completely encloses the J-box and any mounting holes will align with wall studs, if possible.

2. PREPARE THE POWER FEEDS

Mount a 2" x 4" J-box HORIZONTALLY at each power feed location. The J-box with power feed should be mounted at fixture height so it will be concealed when the fixture is installed. Refer to BRACKET DIMENSIONS on back page for more information.

If attaching to an existing vertical J-box, the J-box cover will rotate 90° to cover the J-box, but will be partially visible below the fixture.

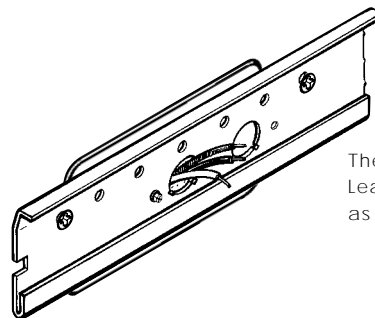

The completed power feed. Leave wire leads at least half as long as fixture to be installed.



SINGLE FIXTURE INSTALLATION

NOTE: 1' fixture length shown. All lengths of Series AIW fixtures follow same instructions to connect and mount a feeder fixture. Refer to BRACKET DIMENSIONS on back page for more information.

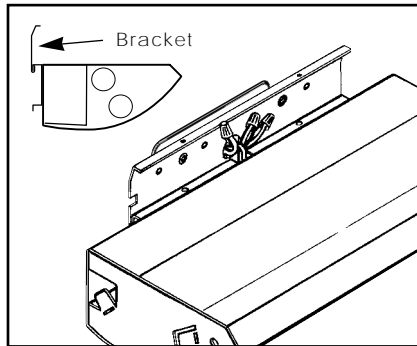

The fixture may hang temporarily from bottom of bracket to facilitate wiring. Wires will feed through the notch at back of fixture to clear bracket.

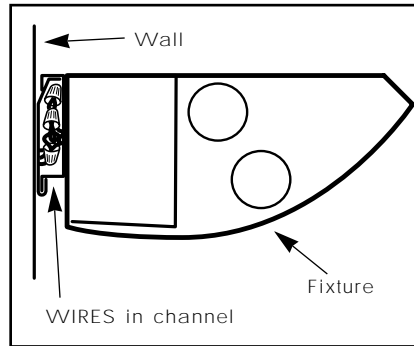

After connecting wires, hang fixture on bracket as shown. Both top and bottom of fixture lock securely, and all wires are enclosed in channel between fixture and wall bracket.

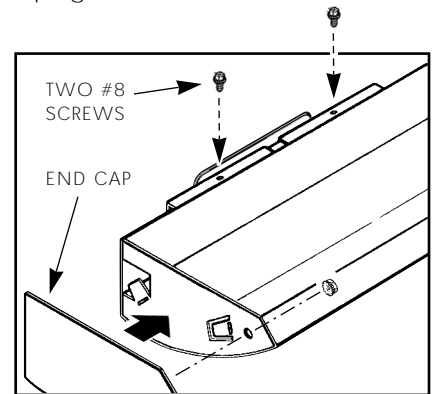

Install two 8 - 32 hex head Phillips screws (included) to secure fixture to mounting bracket. Install one 10 - 32 flange nut (included) to attach each end cap.

Fixture must be grounded in accordance with all local and/or national electrical codes.
Fixture is to be installed in accordance with all local and/or national electrical codes.

CONTINUOUS ROW INSTALLATION

NOTE: 1' fixture length shown below. All lengths of Series AIW fixtures follow same instructions for continuous row installation. Refer to BRACKET DIMENSIONS on back page for more information.

CONNECT FIXTURES WITH:

1. Quick-connect wiring plug
2. Interlocking tabs and slots
3. Screws and flange nuts thru adjoining ends
4. Two 8 - 32 screws attach to wall bracket

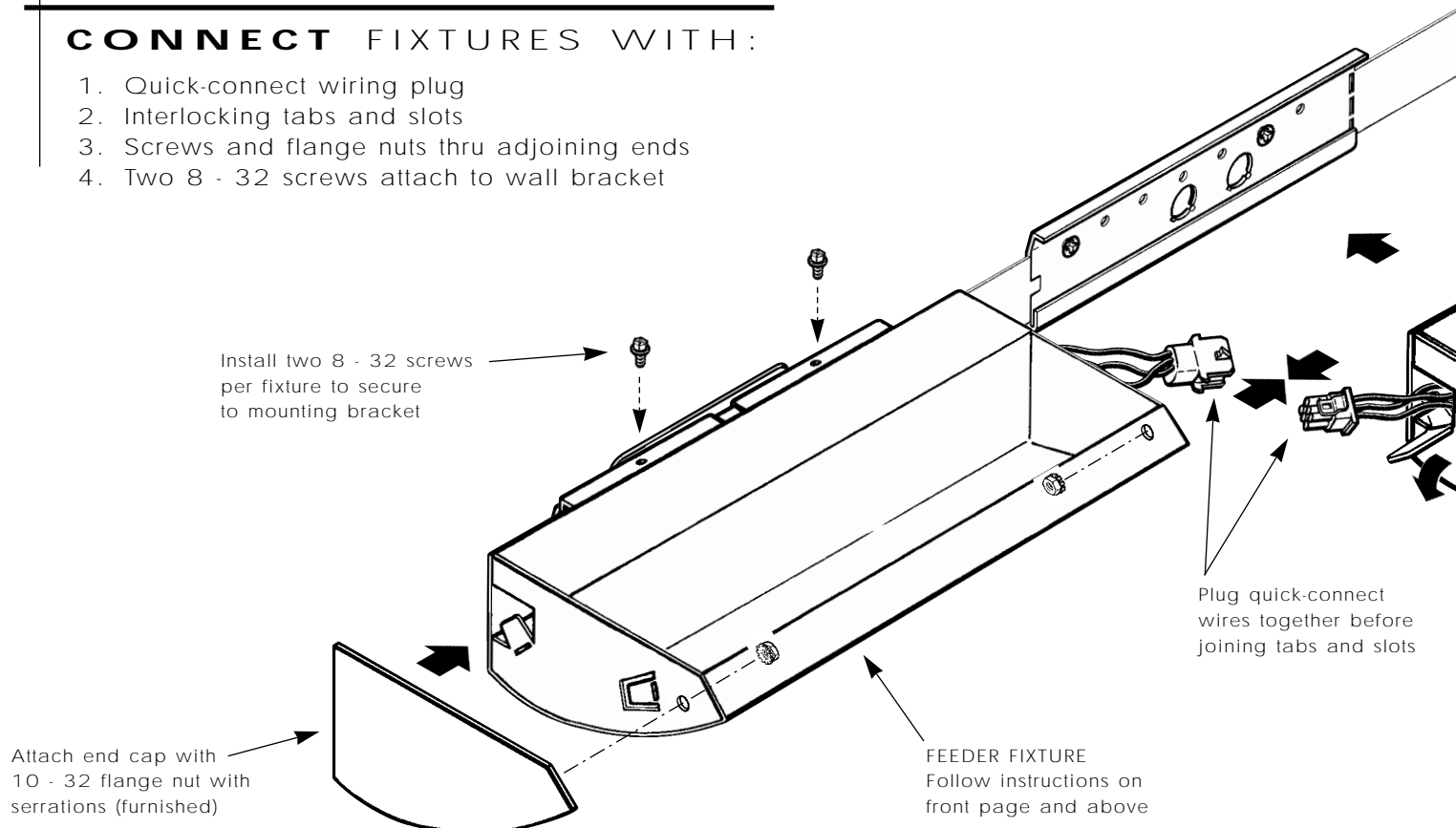

FEEDER & JOINER INFORMATION

Fixtures include all hardware necessary to install except screws used to secure the mounting bracket to the wall. Use hardware appropriate for the surface to which you are mounting.

POWER FEED HARDWARE KIT

Each power feed hardware kit includes:

- 1 Assembly & Installation Instructions
- 1 Wall Mount Bracket
- 1 Junction Box Cover
- 3 Wire Nuts
- 4 8 - 32 x 3/8" Hex Head Phillips Screws
- 2 10 - 32 Flange Nuts with Serrations
- 2 End Caps

JOINER FIXTURE HARDWARE KIT

Each non-power feed hardware kit includes:

- 1 Wall Mount Bracket
- 2 8 - 32 x 3/8" Hex Head Phillips Screws
- 1 10 - 32 x 3/8" Hex Head Phillips Screw
- 1 10 - 32 Flange Nut with Serrations

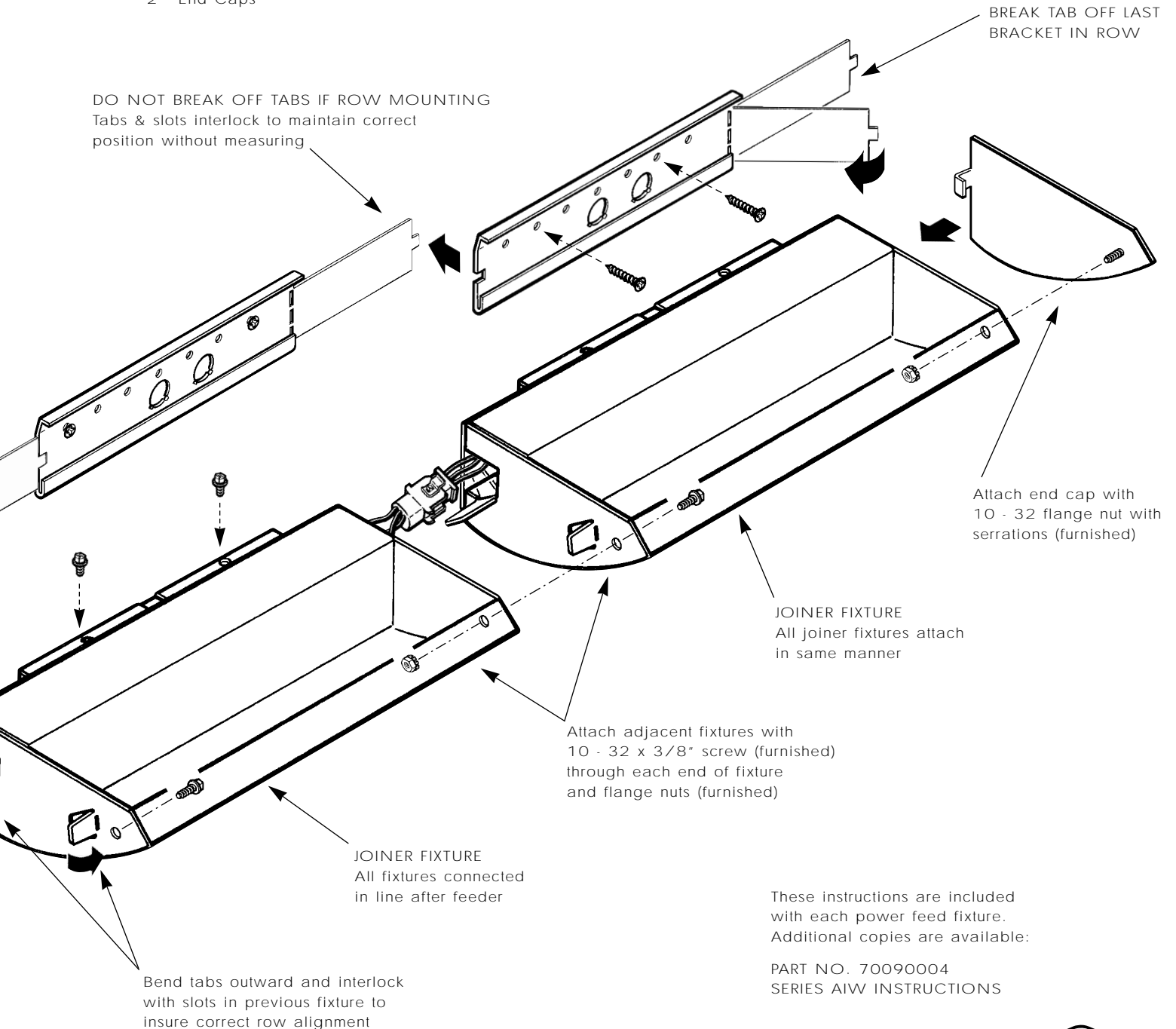

These instructions are included
with each power feed fixture.
Additional copies are available:

PART NO. 70090004
SERIES AIW INSTRUCTIONS



MOUNTING BRACKET DIMENSIONS

All mounting bracket lengths are designed with multiple knockouts and mounting holes for simple installation regardless of wall stud placement.

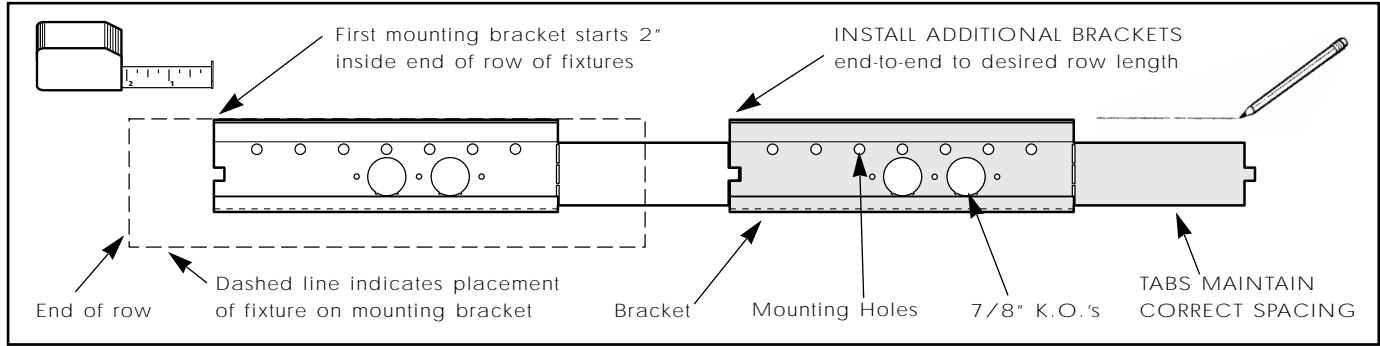

1' FIXTURE BRACKET

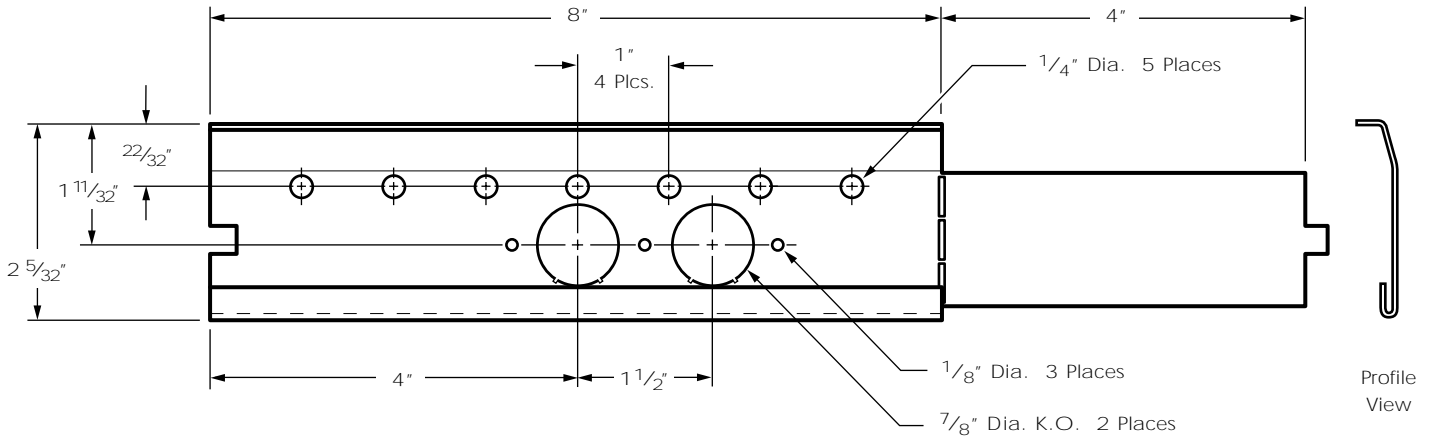

2' FIXTURE BRACKET

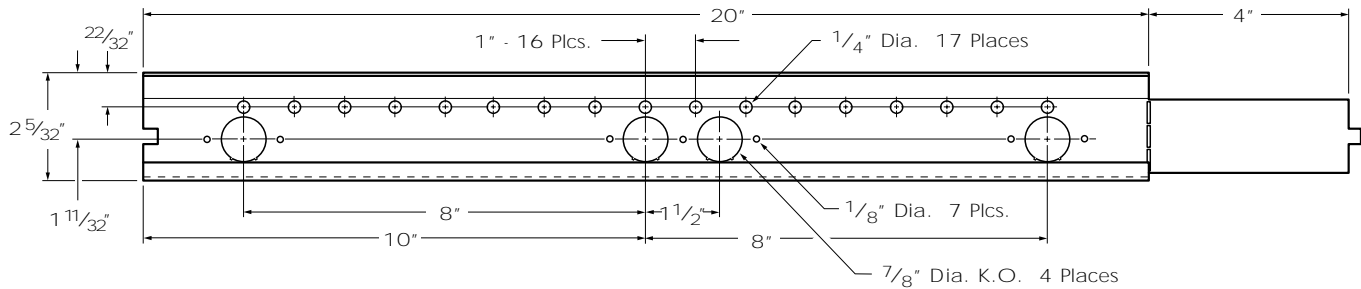

4' FIXTURE BRACKET

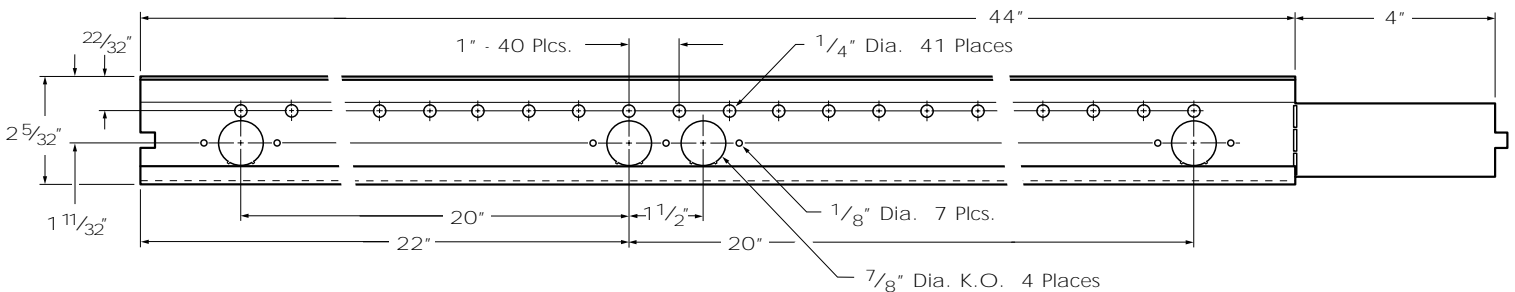

NOTE: 8 FT. LENGTH FIXTURES USE TWO 4 FT. BRACKETS MOUNTED END-TO-END.