

ARCHITECTURAL VANDAL INSTALLATION & INSTRUCTION SHEET

1. Remove two screws holding lens in place, remove lens by sliding towards one end and lifting out. Phillips head screws are supplied, if tamper-proof screws are required replace with the screws packaged inside fixture.

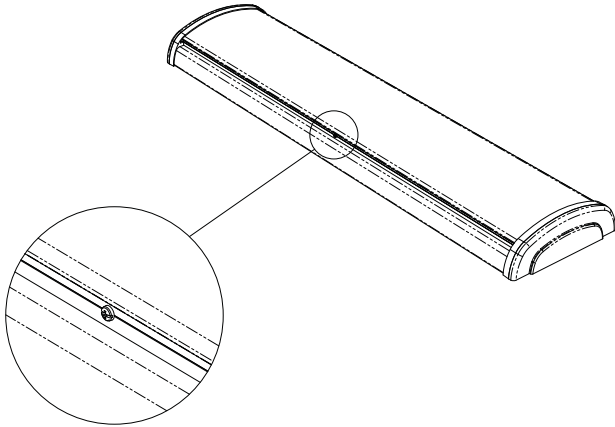

2. Turn quarter-turn fasteners on each end of wireway cover and remove it.
3. Surface mounting: The mounting holes are now exposed on the fixture backplate. Diagram of hole locations is shown below. Secure fixture to mounting surface with fasteners (furnished by others) approved for the application.

4. Pendant Stem Mount: Attach die cast hubs to back of fixture housing using #8 x 1/2" bolts and flange nuts furnished. Screw 3/8" IPS stem into threaded hub and tighten. Attach ceiling mounting brackets for stems to ceiling with fasteners approved for the application (furnished by others). Mount brackets on same centers as die cast hubs. Slide stem canopy over stem. Attach (2) stem lock nuts onto each threaded end of stem, hook lock nuts onto ceiling mounting brackets and tighten. Slide stem canopy over ceiling mounting bracket and secure with set screw on canopy ring.

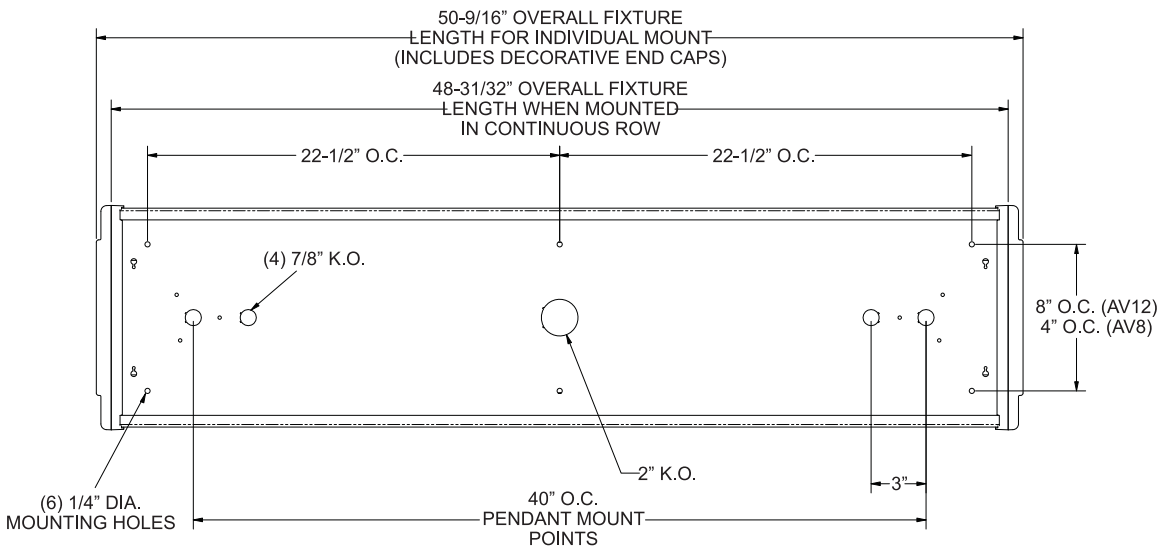
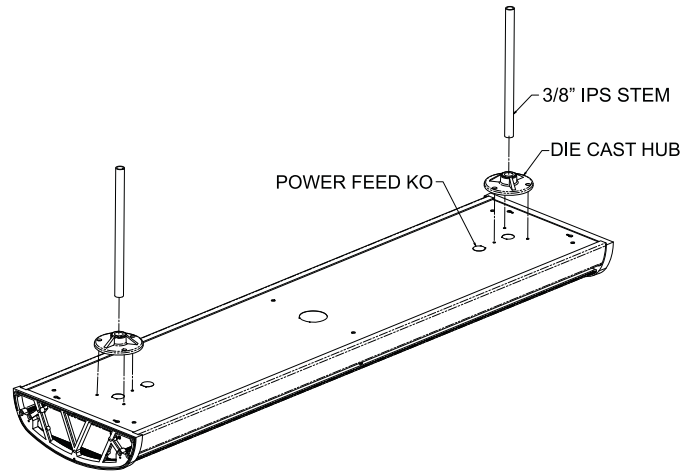

NOTE: An 8' long fixture consists of (2) 4' units bolted together at factory. When surface mounting to ceiling, wall, or corner mounting bracket use all (12) 1/4" dia. mounting holes to secure fixture. When pendant mounting by stem, aircraft cable, etc., use a pendant hanger every 4' (nominal).



- 5.** Row mounting: Prior to mounting fixtures in continuous row, remove decorative end caps at each fixture junction. If specified with quick-connect wiring harness, plug harnesses together. Place fixtures together, tabs and slots on endplates will align fixtures, and bolt together with 8-32x1-3/4" screws and 8-32 nuts (furnished).

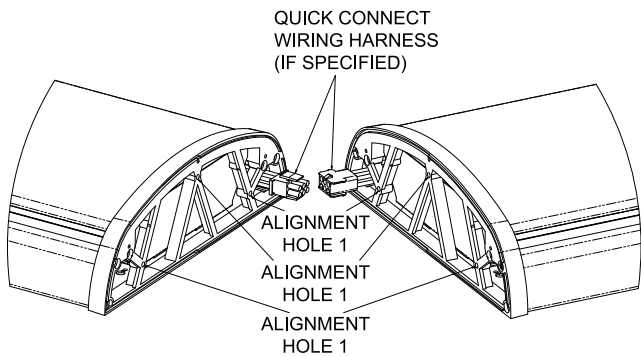

- 6.** Finish all electrical connections, reinstall wireway cover, install lamps and replace lens.

- 7.** Corner mounting: Corner mount assembly is shipped configured for individual fixture installation with endplates installed. If row mounted, remove endplates at fixture junction before mounting.

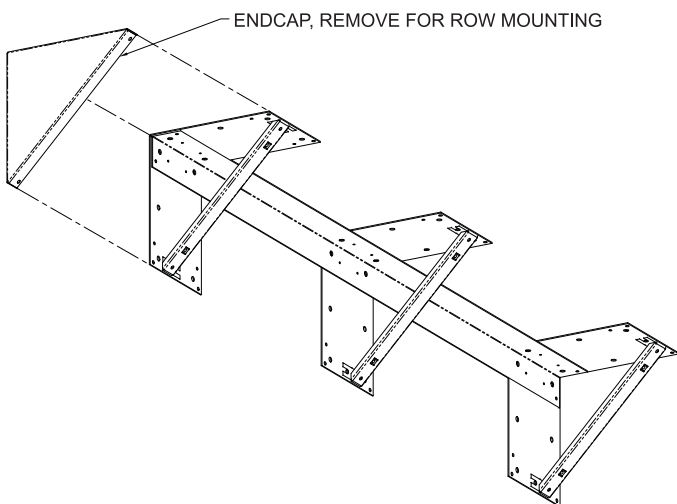

- 8.** Place corner mount in desired location and fasten in place with fasteners approved for the application (furnished by others). 24 locations are provided per 4' section. Use an adequate number of fasteners to provide a secure mounting. Remove lens and wireway cover from fixture per steps 1 and 2 of these instructions.

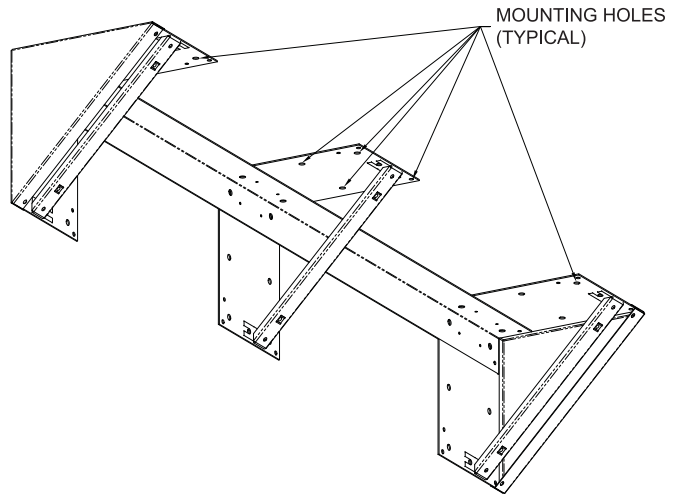

- 9.** Position fixture over corner mounting bracket and secure with 1/4-20 screws (furnished). If row mounting, align, bolt, and fasten wiring harness per step 5 of these instructions. Finish electrical connections, reinstall the wireway cover, lamps, and lens per step 6.

