



OUTDOOR LIGHTING

OSA BOLLARDS

**INSTALLATION
AND
ASSEMBLY**

Read instructions carefully before attempting to install fixture.
Retain instructions for future reference.

Warnings:

- This product must be installed in accordance with the applicable installation code by a person familiar with the construction and operation of the product and the hazards involved.
- Make sure all electrical power is turned off while installing the fixture.
- This fixture must be adequately grounded for protection against shock hazards and to assure proper operation.
- External parts of fixture develop high operating temperature. To avoid pain or injury, do not touch external parts of fixture when it is in operation.
- Disconnect power before servicing.
- Always use correct lamp type and wattage.
- All gaskets and sealing surfaces must be kept clean during installation.

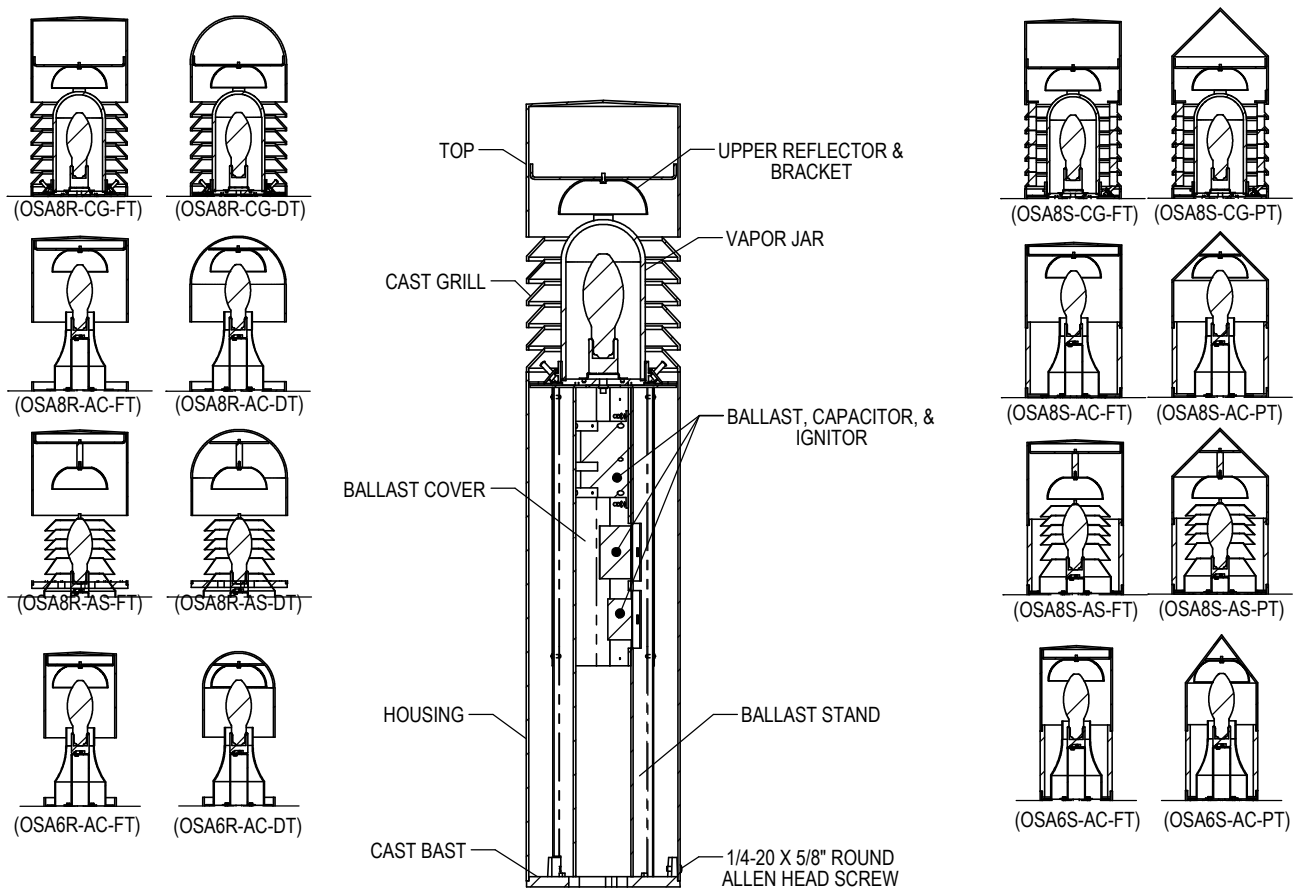

OSA BOLLARDS

INSTALLATION AND ASSEMBLY

1. POWER IS SUPPLIED TO THE FIXTURE THROUGH ELECTRICAL CONDUIT THAT SHOULD EXTEND 6" ABOVE FINISH GRADE. THE CONDUIT ENTERS THE FIXTURE THROUGH THE BASE AS INDICATED ON THE INCLUDED ANCHOR BOLT TEMPLATE.
2. PREPARE FOR AN ADEQUATE CONCRETE BASE THAT WILL FULLY SURROUND THE ANCHOR BOLTS. THE CONCRETE BASE SURFACE SHOULD BE LEVEL AND THE SURFACE AREA SHOULD BE NO LESS THAN THE CAST BASE SIZE.
3. DECIDE ON THE BOLLARD ORIENTATION. POSITION THREE ANCHOR BOLTS INTO THE CONCRETE USING THE INCLUDED ANCHOR BOLT TEMPLATE TO ACHIEVE THE DESIRED ORIENTATION. THE MINIMUM LENGTH THE ANCHOR BOLTS SHOULD EXTEND PAST THE LEVELED GRADE IS 2", MAXIMUM BEING 3". (SEE FIG. #1)

ANCHOR BOLT TEMPLATE,
USED FOR FIELD DRILLED
ANCHORS OR OPTIONAL
J BOLTS

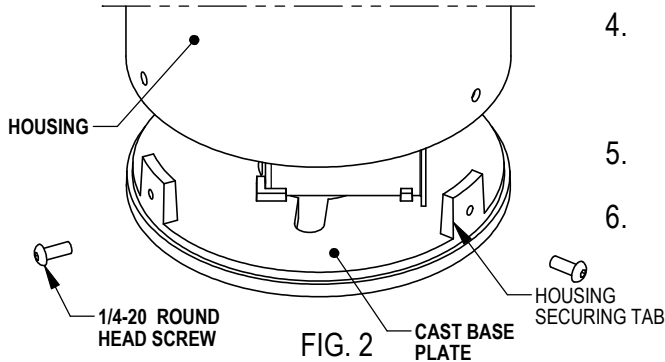
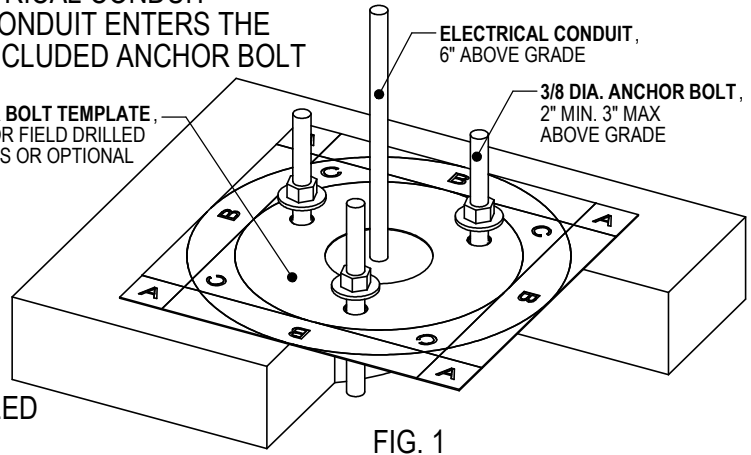

4. REMOVE THE, 3 FOR ROUND & 4 FOR SQUARE, 1/4-20 ROUND ALLEN HEAD SCREWS LOCATED AT THE BASE OF THE BOLLARD HOUSING. LIFT THE HOUSING STRAIGHT UP TO SEPARATE FROM THE CAST BASE AND INNER ASSEMBLY. (SEE FIG. 2)
5. CAREFULLY PLACE THE CAST BASE ASSEMBLY ONTO THE ANCHOR BOLTS AND PLUMB. (SEE FIGURE #3)
6. MAKING SURE THE POWER IS TURNED OFF; CONNECT THE SUPPLY WIRES AS FOLLOWS: BLACK TO BLACK, WHITE TO WHITE, & GREEN TO GROUND.

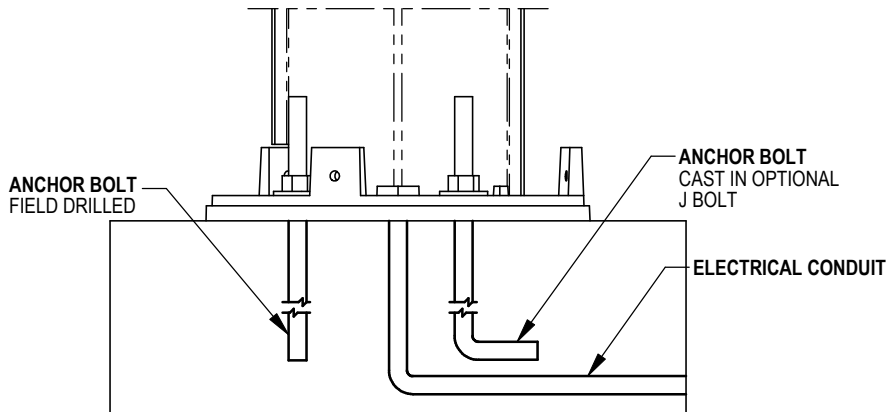

7. INSTALL THE PROPER LAMP TYPE AND WATTAGE. IN CAST LOUVERED STYLE BOLLARDS, UNSCREW THE VAPOR JAR FROM THE CAST SCREW SHELL. INSTALL THE LAMP AND SCREW THE VAPOR JAR BACK INTO THE SCREW SHELL. (SEE FIG. 4)
8. PLACE THE BALLAST HOUSING OVER THE INNER ASSEMBLY AND BACK ONTO THE CAST BASE. MAKE SURE ALL GASKETS AND SEALING SURFACES ARE CLEAN AND IN PLACE. SECURE USING THE 1/4-20 ROUND ALLEN HEAD SCREWS.

