

**SPECIFICATIONS**

- HOUSING – 20-gauge die-formed, welded C.R.S.
- DOOR FRAME – 20-gauge C.R.S. or 0.050" extruded aluminum with mitered corners.
- SHIELDING – Clear acrylic prismatic lens standard.
- FINISH – 92% minimum average reflective white powder coat with multi-stage iron/phosphate prepared metal.
- ELECTRICAL – Electronic ballast standard, either instant start or programmed start, rated Class P.
- LABELS – UL/CUL listed as as fluorescent luminaire suitable for dry or damp locations.
- MOUNTING – Surface or suspended.

**FEATURES**

- Fully-enclosed spring-loaded cam latches allow years of hassle-free maintenance.
- Mitered corners provide clean, crisp appearance with no visible rivets or screws.
- Welded end plates ensure durable, rigid construction.
- Fully gasketed door minimizes contaminants.
- Matte white acrylic side panels provide soft, luminous appearance.
- Ballast secured by two captive bolts and nuts to ensure a tight, reliable fit for maximum heat dissipation and minimal ballast noise.
- All parts painted after fabrication to facilitate installation, increase efficiency, and inhibit corrosion.
- This fixture is proudly made in the USA.

**SUBMITTAL INFORMATION**

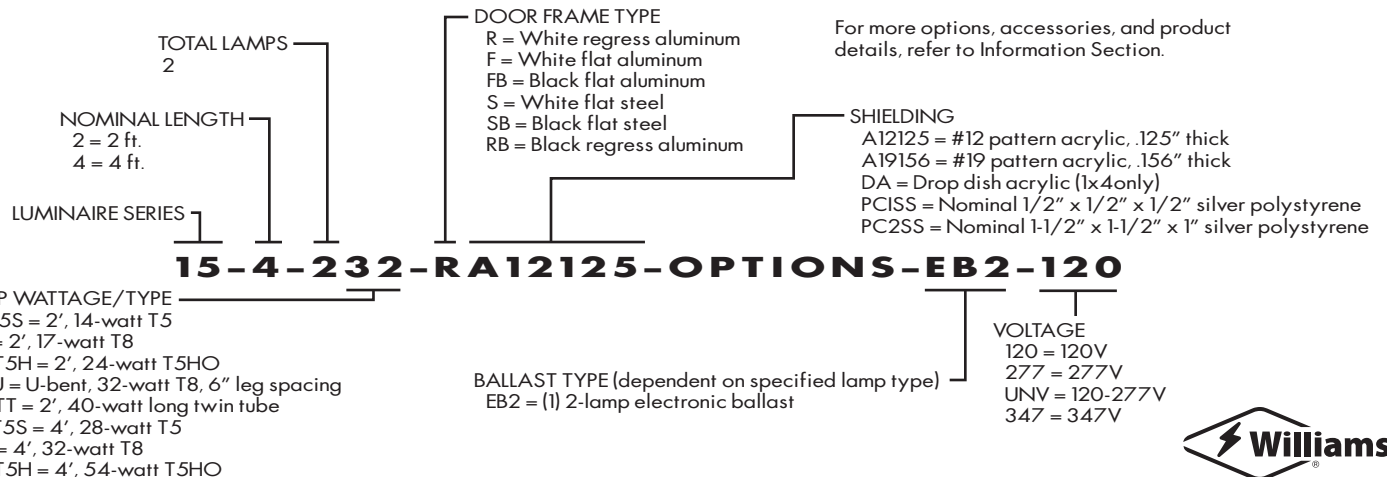

FLUORESCENT LIGHTING

Williams Catalog #15-4-232-FA12125-EB2-120  
 Test Report #8456.0, Dated 10/04/95

Lamp Type: F32T8/SPX35/RS  
 Lamp Quantity: 2

### CANDLEPOWER DISTRIBUTION

VERT. ANG.	HORIZONTAL ANGLE			ZONAL LUMENS
	0	45	90	
0	1476.	1476.	1476.	
5	1460.	1463.	1466.	139.7
15	1432.	1453.	1460.	411.2
25	1304.	1333.	1343.	614.7
35	1094.	1114.	1099.	694.1
45	797.	826.	862.	639.6
55	458.	537.	570.	474.4
65	243.	293.	352.	298.7
75	125.	191.	279.	212.1
85	43.	133.	190.	138.2
90	3.	87.	139.	
95	0.	82.	133.	82.8
105	0.	81.	128.	78.0
115	0.	73.	113.	66.1
125	0.	66.	100.	53.8
135	0.	55.	84.	38.7
145	0.	50.	71.	28.0
155	0.	34.	48.	14.3
165	0.	27.	35.	6.8
175	0.	7.	8.	.5
180	0.	0.	0.	

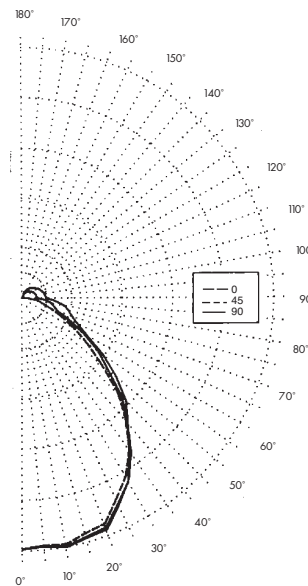

### LUMEN SUMMARY

ZONE	LUMENS	% LAMP	% FIXTURE
0 - 30	1166.	19.8	29.2
0 - 40	1860.	31.5	46.6
0 - 60	2974.	50.4	74.5
0 - 90	3623.	61.4	90.8
90 - 120	227.	3.8	5.7
90 - 130	281.	4.8	7.0
90 - 150	348.	5.9	8.7
90 - 180	369.	6.3	9.2
Total Luminaire			
0-180	3992.	67.7	100.0

### ZONAL CAVITY COEFFICIENTS

EFFECTIVE FLOOR CAVITY REFL. = .20

CEILING	.80			.70			.50			
	WALL	.70	.50	.30	.70	.50	.30	.50	.30	.10
0		.79	.79	.79	.76	.76	.76	.72	.72	.72
1		.73	.70	.67	.70	.67	.65	.64	.62	.60
2		.67	.62	.58	.65	.60	.56	.57	.53	.51
3		.62	.55	.50	.60	.54	.49	.51	.47	.44
4		.57	.49	.44	.55	.48	.43	.46	.42	.38
5		.52	.44	.39	.50	.43	.38	.41	.37	.33
6		.48	.40	.34	.47	.39	.34	.37	.33	.29
7		.45	.36	.31	.43	.35	.30	.34	.29	.26
8		.41	.33	.27	.40	.32	.27	.30	.26	.23
9		.38	.29	.24	.37	.29	.24	.27	.23	.20
10		.35	.27	.22	.34	.26	.21	.25	.21	.18

### TOTAL LUMINAIRE

OPTICAL EFFICIENCY = 67.7 %

SPACING CRITERIA: ACROSS= 1.2 ALONG= 1.2

## BACK VIEW

A. Midsection punching available only on 4' unit

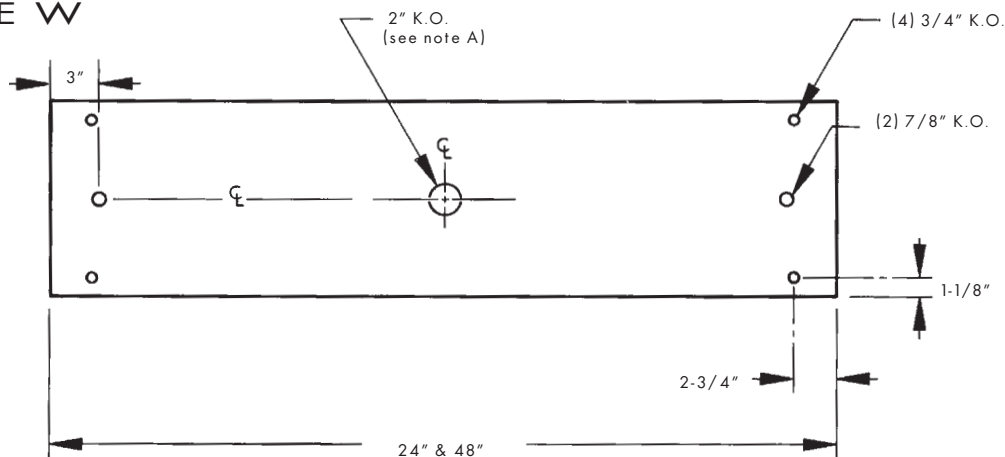

FLUORESCENT LIGHTING