

# HISTORIC ROUND ALUMINUM POLE

# HWNR

**SUBMITTAL:**

**JOB:**

**TYPE:**

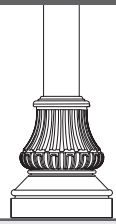

EXAMPLE:

**VM - HWNR - A - 080 - 40 - 40 - 125 - S - T238 - DBR - AB - OPTIONS**

PREFIX      SERIES      MATERIAL      HEIGHT      TOP DIAMETER      SHAFT BASE DIAMETER      WALL THICKNESS      SHAPE OF SHAFT      FIXTURE MOUNTING      FINISH OPTIONS      ANCHOR BOLTS      OPTIONS

## SERIES

**HWNR** — Series HWNR is available in 8' to 18' pole heights including a cast aluminum structural base with a choice of straight or tapered smooth round shafts. The pole is designed to accommodate up to two fixtures on a pole top assembly with a maximum 36" O.C. fixture span.

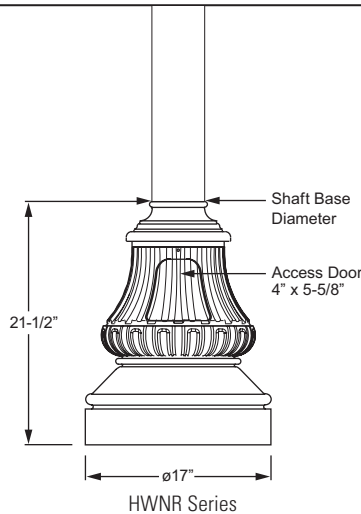

## HWNR SERIES

**SHAFT** — The pole shaft is either spun or extruded from 6063 alloy aluminum.

**POLE TOP** — A pole top plate and tenon (must specify size) are provided for top mount luminaire or Williams' pole top assembly. A removable finial is available for poles receiving drilling patterns for side-mount luminaire arm assemblies.

**ACCESS DOOR** — The structural base includes an access door for easy on-site maintenance.

**STRUCTURAL BASE** — The structural base is cast from 356 alloy aluminum. A grounding provision with hardware is provided. The pole is inserted and welded into the structural base casting. The completed assembly is heat-treated to a T6 temper after the structural welding is completed.

## MATERIAL (Must specify)

**A** Aluminum

## HEIGHT (Must specify)

<b>080</b>	8'	<b>100</b>	10'	<b>120</b>	12'
<b>140</b>	14'	<b>160</b>	16'	<b>180</b>	18'

## TOP DIAMETER (Must specify according to chart on page 14C.)

<b>40</b>	4"	<b>50</b>	5" (Straight round shaft only)
<b>60</b>	6" (Straight round shaft only)		

## SHAFT BASE DIAMETER (Top diameter of the decorative base casting. Must specify according to chart on page 14C.)

<b>40</b>	4" (Straight round shaft only)	<b>50</b>	5"
<b>60</b>	6"		

## WALL THICKNESS (Must specify according to chart on page 14C.)

<b>125</b>	0.125"
<b>188</b>	0.188" (16' and 18' shaft heights only)

## SHAFT SHAPE

Shafts are available in straight or tapered styles with a smooth surface.

## SHAPE OF SHAFT (Must specify)

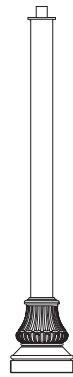

**S**  
Straight Round

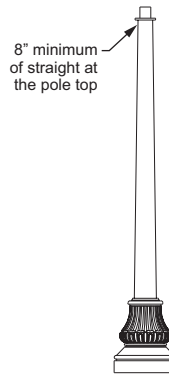

**T**  
Tapered Round

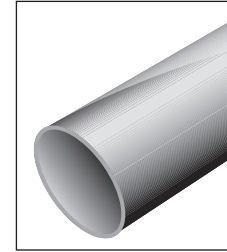

SHAFT DETAIL

## FIXTURE MOUNTING

Designed for pole top tenon or drilled side mount. See Williams' Pole Top Assemblies for various fixture mounting tenon and arm assemblies.

### RADIAL INDEX

The Radial Index references how parts are oriented around the shaft. A degree measurement is used from a base point. The standard base point of reference is the access door. Degrees are measured in a clockwise motion as viewed from the top of the shaft.

## FIXTURE MOUNTING (Must specify)

### POLE TOP MOUNT

<b>T238</b>	2-3/8" O.D. x 4" Round Tenon
<b>T278</b>	2-7/8" O.D. x 4" Round Tenon
<b>T33</b>	3" O.D. x 3" Round Tenon (Use with Williams' Historic Pole Top Assemblies)
<b>T312</b>	3-1/2" O.D. x 12" Round Tenon (Use with Williams' AVPT Decorative Pole Top Assemblies)
<b>TC_---</b>	Custom Round Tenon (Must specify tenon diameter (O.D.) and height, consult factory)

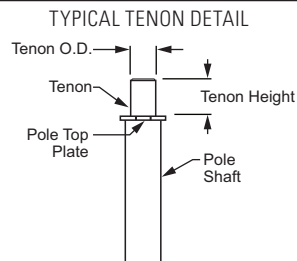

### DRILLED SIDE MOUNT

Must specify drilling location using codes below. See radial index for clarification. Note: Minimum 8" of straight provided at top of pole. Consult factory for details.

**EXAMPLE: sm/s**  
(Side mount drill, single fixture located at 0°)

### RADIAL INDEX

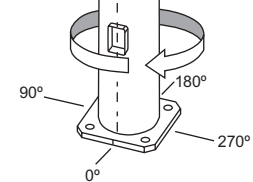
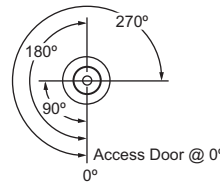

**SM/S**  
Side Mount Drill/Single 0°  
(Located at 0°)



**SM/D90**  
Side Mount Drill/Double 90°  
(Located at 0° and 90°)



**SM/D180**  
Side Mount Drill/Double 180°  
(Located at 0° and 180°)



**SM/T90**  
Side Mount Drill/Triple 90°  
(Located at 0°, 90°, and 180°)



**SM/T120**  
Side Mount Drill/Triple 120°  
(Located at 0°, 120°, and 240°)

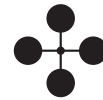

**SM/Q90**  
Side Mount Drill/Quad 90°  
(Located at 0°, 90°, 180°, and 270°)

## FINISH OPTIONS

Polyester powder coat applied over chromate pre-treatment.

## FINISH OPTIONS (Must specify)

<b>BLK</b>	Black (RAL# 9004)	<b>DBR</b>	Dark Bronze (Protech #PC21462)
<b>GRAY</b>	Standard Gray (Protech #PC18367)	<b>GRN</b>	Green (RAL# 6005)
<b>SLV</b>	Satin Aluminum (RAL# 9006)	<b>WHT</b>	White (RAL# 9003)
<b>RAL#_---</b>	Specify Custom Color		

## ANCHOR BOLTS (Must specify)

## ANCHOR BOLTS

Anchor bolts conform to ASTM F1554 Grade 55 and are provided with two hex nuts and two flat washers. Bolts have an "L" bend on one end and are galvanized a minimum of 12" on the threaded end. Template provided with every pole and anchor bolt order.

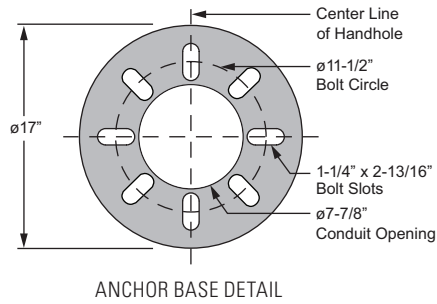
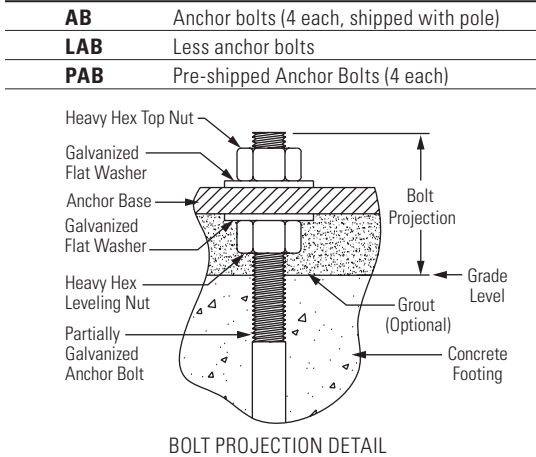

STRUCTURAL BASE				ANCHOR BOLTS <sup>1</sup>		
BOLT CIRCLE		DIA. (IN)	THK. (IN)	BOLT SIZE (IN)	PROJECTION (IN)	± (IN)
DIA. (IN)	± (IN)					
11-1/2	1-1/2	17	3/4	3/4 x 17 x 3	3-1/2	1/4

<sup>1</sup> Provided with four anchor bolts. Base has eight slots for additional orientation.

## OPTIONS

**FS** Festoon Box only

**NOTE: Casting only. Outlet, cover and hardware by others. The festoon box is located above the access door at 0°.**

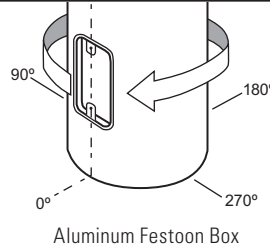

## ACCESSORIES

**FINIALS** (For poles with side-mount drill only, for additional finial options consult factory)



**B** Ball



**D** Needle



**V** Burnsville



**W** Woodbridge

## LOAD AND DIMENSIONAL DATA (Continued on back)

### STRAIGHT ROUND

POLE HT. (FT.)	CATALOG NUMBER	SHAFT				80 MPH <sup>2,3</sup>		90 MPH <sup>2,3</sup>		100 MPH <sup>2,3</sup>	
		TOP O.D. (IN)	BASE O.D. (IN)	WALL THK. (IN)	STRUC. WT. <sup>4</sup> (LBS)	MAX LUMINAIRE EPA (SQ FT)	MAX LUMINAIRE WEIGHT (LBS)	MAX LUMINAIRE EPA (SQ FT)	MAX LUMINAIRE WEIGHT (LBS)	MAX LUMINAIRE EPA (SQ FT)	MAX LUMINAIRE WEIGHT (LBS)
8	HWNR-A-080-40-40-125-S	4	4	.125	67	13.3	300	10.2	300	8.0	300
	HWNR-A-080-50-50-125-S	5	5	.125	69	21.9	300	17.0	300	13.4	300
10	HWNR-A-100-40-40-125-S	4	4	.125	70	9.1	300	6.8	300	5.2	300
	HWNR-A-100-50-50-125-S	5	5	.125	73	15.5	300	11.8	300	9.1	300
12	HWNR-A-120-40-40-125-S	4	4	.125	74	6.3	300	4.5	300	3.2	300
	HWNR-A-120-50-50-125-S	5	5	.125	78	11.2	300	8.3	300	6.2	300
14	HWNR-A-140-50-50-125-S	5	5	.125	82	8.1	300	5.7	300	4.0	300
16	HWNR-A-160-50-50-125-S	5	5	.125	87	5.7	300	3.7	300	2.2	300
	HWNR-A-160-60-60-188-S	6	6	.188	112	16.6	300	12.1	300	8.9	300
18	HWNR-A-180-50-50-125-S	5	5	.125	91	3.7	300	1.9	300	-	300
	HWNR-A-180-60-60-188-S	6	6	.188	120	12.9	300	9.1	300	6.3	300

<sup>2</sup> Effective Projected Area (EPA) calculations allow for 1.3 Wind Gust Factor. Maximum EPA and weight values are based on top mounted luminaires or arm assembly having a centroid 2'-6" above and 1'-6" eccentric to the pole top at Nominal Mounting Height. Variations from sizes listed above are available upon inquiry. Satisfactory performance of poles is dependent upon the pole being properly attached to a supporting foundation of adequate design. See Williams Outdoor Information Section, page 6, for Load and Dimensional Data specifics.

<sup>3</sup> Wind map provided in Williams Outdoor information section, pole information page 6.

<sup>4</sup> Structure Weight is a nominal value which includes the pole shaft and structural base.

## LOAD AND DIMENSIONAL DATA (Cont'd)

### TAPERED ROUND

POLE HT. (FT.)	CATALOG NUMBER	SHAFT				80 MPH <sup>2,3</sup>		90 MPH <sup>2,3</sup>		100 MPH <sup>2,3</sup>	
		TOP O.D. (IN)	BASE O.D. (IN)	WALL THK. (IN)	STRUC. WT. <sup>4</sup> (LBS)	MAX LUMINAIRE EPA (SQ FT)	MAX LUMINAIRE WEIGHT (LBS)	MAX LUMINAIRE EPA (SQ FT)	MAX LUMINAIRE WEIGHT (LBS)	MAX LUMINAIRE EPA (SQ FT)	MAX LUMINAIRE WEIGHT (LBS)
8	HWNR-A-080-40-50-125-T	4	5	.125	67	21.9	300	17.0	300	13.4	300
10	HWNR-A-100-40-50-125-T	4	5	.125	71	15.5	300	11.8	300	9.1	300
12	HWNR-A-120-40-50-125-T	4	5	.125	75	11.2	300	8.3	300	6.2	300
	HWNR-A-120-40-60-125-T	4	6	.125	77	17.4	300	13.1	300	10.0	300
14	HWNR-A-140-40-50-125-T	4	5	.125	79	8.1	300	5.7	300	4.0	300
	HWNR-A-140-40-60-125-T	4	6	.125	82	13.1	300	9.5	300	6.9	300
16	HWNR-A-160-40-50-125-T	4	5	.125	83	5.7	300	3.7	300	2.2	300
	HWNR-A-160-40-50-188-T	4	5	.188	98	10.3	300	7.3	300	5.2	300
	HWNR-A-160-40-60-125-T	4	6	.125	86	9.7	300	6.7	300	4.5	300
18	HWNR-A-180-40-50-125-T	4	5	.125	87	3.7	300	1.9	300	-	300
	HWNR-A-180-40-60-125-T	4	6	.125	91	7.0	300	4.4	300	2.5	300
	HWNR-A-180-40-60-188-T	4	6	.188	109	10.3	300	7.3	300	5.2	300

<sup>2</sup> Effective Projected Area (EPA) calculations allow for 1.3 Wind Gust Factor. Maximum EPA and weight values are based on top mounted luminaires or arm assembly having a centroid 2'-6" above and 1'-6" eccentric to the pole top at Nominal Mounting Height. Variations from sizes listed above are available upon inquiry. Satisfactory performance of poles is dependent upon the pole being properly attached to a supporting foundation of adequate design. See Williams Outdoor Information Section, page 6, for Load and Dimensional Data specifics.

<sup>3</sup> Wind map provided in Williams Outdoor information section, pole information page 6.

<sup>4</sup> Structure Weight is a nominal value which includes the pole shaft and structural base.

- Pole installations in various parts of the country perform satisfactorily; however, in select locations destructive vibration can occur. H.E. Williams, Inc. is not responsible for vibration induced fatigue damage.

- H.E. Williams, Inc. warrants this product to be free from defects in materials and workmanship. Any defective part returned within one year from the date of delivery of the goods will be repaired or replaced without charge, F.O.B. factory.

This warranty specifically excludes fatigue or similar phenomena resulting from induced vibration, harmonic oscillation or resonance associated with movement of air currents around the product.

The above warranties are given in lieu of all other warranties express or implied, including without limitation, the warranty of merchantability and the warranty of suitability for a particular purpose. It is expressly stated that H.E. Williams, Inc. assumes no liability for consequential or liquidated damages arising out of a breach of the sale, including any warranties arising therefrom, and buyer's remedy shall be limited to repair or replacement of defective parts as described above.

Any action for the breach under a sale including any warranties arising therefrom must be commenced within one year after the cause of action accrues.