

# HISTORIC 16-FLAT FLUTED ALUMINUM POLE WITH SQUARE BASE

# HWLF

**SUBMITTAL:**

**JOB:**

**TYPE:**



**EXAMPLE:** **VM - HWLF - A - 080 - 40 - 40 - 125 - S - T238 - DBR - AB - OPTIONS**

PREFIX      SERIES      MATERIAL      HEIGHT      TOP DIAMETER      SHAFT BASE DIAMETER      WALL THICKNESS      SHAPE OF SHAFT      FIXTURE MOUNTING      FINISH OPTIONS      ANCHOR BOLTS      OPTIONS

## SERIES

**HWLF** — Series HWLF is available in 8' to 14' pole heights including a cast aluminum structural base with a choice of straight or tapered 16-flat fluted round shafts. The pole is designed to accommodate up to two fixtures on a pole top assembly with a maximum 36" O.C. fixture span.

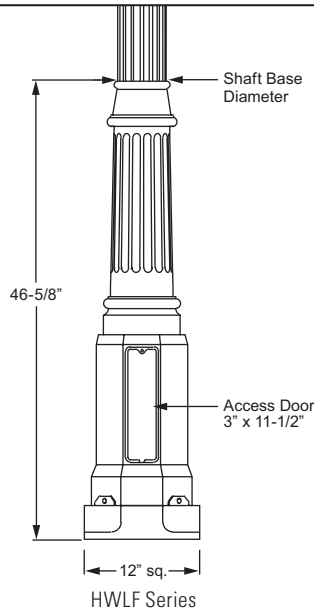

## HWLF SERIES

**SHAFT** — The pole shaft is either spun or extruded from 6063 alloy aluminum.

**POLE TOP** — A pole top plate and tenon (must specify size) are provided for top mount luminaire or Williams' pole top assembly.

**ACCESS DOOR** — The structural base includes an access door for easy on-site maintenance.

**STRUCTURAL BASE** — The structural base is cast from 356 alloy aluminum. A grounding provision with hardware is provided. The pole is inserted and welded into the structural base casting. The completed assembly is heat-treated to a T6 temper after the structural welding is completed.

## MATERIAL (Must specify)

**A** Aluminum

## HEIGHT (Must specify)

<b>080</b>	8'	<b>100</b>	10'	<b>120</b>	12'
<b>140</b>	14'				

## TOP DIAMETER (Must specify according to chart on page 11C.)

<b>40</b>	4" Straight Fluted	<b>50</b>	5" Straight Fluted
<b>TF</b>	Tapered Fluted (Top diameter varies, see chart on page 11C)		

## SHAFT BASE DIAMETER (Top diameter of the decorative base casting. Must specify according to chart on page 11C.)

<b>40</b>	4" (Straight round shaft only)	<b>50</b>	5"
-----------	--------------------------------	-----------	----

## WALL THICKNESS (Must specify)

<b>125</b>	0.125"
------------	--------

### SHAFT SHAPE

Shafts are available in straight or tapered styles with a 16-Flat Fluted Round surface.

### SHAPE OF SHAFT (Must specify)

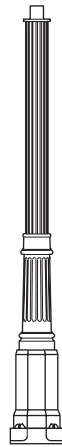

**S**  
Straight Round

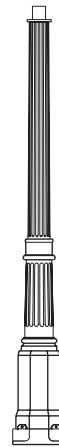

**T**  
Tapered Round

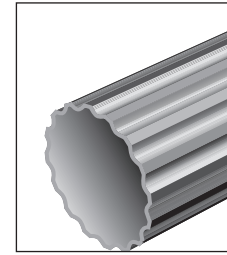

SHAFT DETAIL  
16-Flat Fluted Round

### FIXTURE MOUNTING

Designed for pole top tenon. See Williams' Pole Top Assemblies for various fixture mounting tenon and arm assemblies.

### FIXTURE MOUNTING (Must specify)

<b>T238</b>	2-3/8" O.D. x 4" Round Tenon
<b>T278</b>	2-7/8" O.D. x 4" Round Tenon
<b>T33</b>	3" O.D. x 3" Round Tenon (Use with Historic Pole Top Assemblies)
<b>T312</b>	3-1/2" O.D. x 12" Round Tenon (Use with Williams' AVPT Decorative Pole Top Assemblies)
<b>TC ____</b>	Custom Round Tenon (Must specify tenon diameter (O.D.) and height, consult factory)

### TYPICAL TENON DETAIL

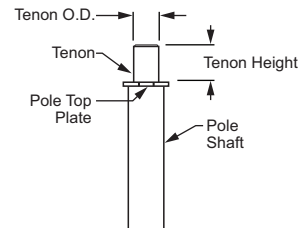

### FINISH OPTIONS

Polyester powder coat applied over chromate pre-treatment.

### FINISH OPTIONS (Must specify)

<b>BLK</b>	Black (RAL# 9004)	<b>DBR</b>	Dark Bronze (Protech #PC21462)
<b>GRAY</b>	Standard Gray (Protech #PC18367)	<b>GRN</b>	Green (RAL# 6005)
<b>SLV</b>	Satin Aluminum (RAL# 9006)	<b>WHT</b>	White (RAL# 9003)
<b>RAL# ____</b>	Specify Custom Color		

### ANCHOR BOLTS

Anchor bolts conform to ASTM F1554 Grade 55 and are provided with two hex nuts and two flat washers. Bolts have an "L" bend on one end and are galvanized a minimum of 12" on the threaded end. Template provided with every pole and anchor bolt order.

### ANCHOR BOLTS (Must specify)

<b>AB</b>	Anchor bolts (4 each, shipped with pole)
<b>LAB</b>	Less anchor bolts
<b>PAB</b>	Pre-shipped Anchor Bolts (4 each)

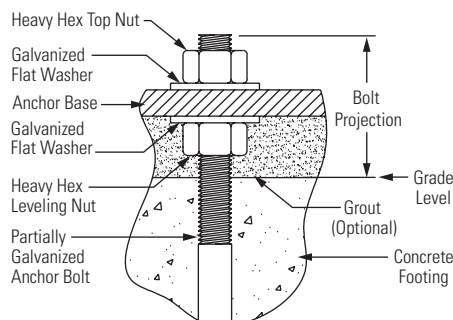

BOLT PROJECTION DETAIL

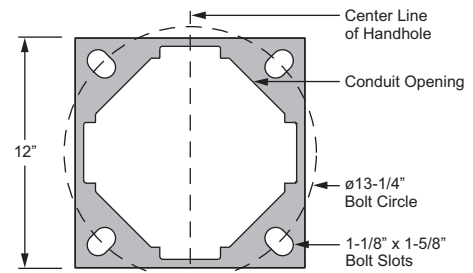

ANCHOR BASE DETAIL

STRUCTURAL BASE				ANCHOR BOLTS		
BOLT CIRCLE		SQ. (IN)	THK. (IN)	BOLT SIZE (IN)	PROJECTION (IN)	± (IN)
DIA. (IN)	± (IN)					
13-1/4	1/2	12	3/4	3/4 x 17 x 3	3-1/2	1/4

## OPTIONS

**FS** Festoon Box only

**NOTE: Casting only. Outlet, cover and hardware by others. The festoon box is located above the access door at 0°.**

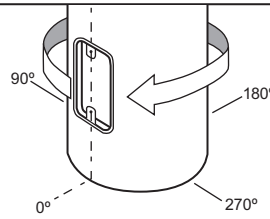

Aluminum Festoon Box

## LOAD AND DIMENSIONAL DATA

### STRAIGHT FLUTED ROUND

POLE HT. (FT.)	CATALOG NUMBER	SHAFT				80 MPH <sup>1,2</sup>		90 MPH <sup>1,2</sup>		100 MPH <sup>1,2</sup>	
		TOP O.D. (IN)	BASE O.D. (IN)	WALL THK. (IN)	STRUC. WT. <sup>3</sup> (LBS)	MAX LUMINAIRE EPA (SQ FT)	MAX LUMINAIRE WEIGHT (LBS)	MAX LUMINAIRE EPA (SQ FT)	MAX LUMINAIRE WEIGHT (LBS)	MAX LUMINAIRE EPA (SQ FT)	MAX LUMINAIRE WEIGHT (LBS)
8	HWLF-A-080-40-40-125-S	4	4	.125	80	13.3	300	10.2	300	8.0	300
	HWLF-A-080-50-50-125-S	5	5	.125	80	21.9	300	17.0	300	13.4	300
10	HWLF-A-100-40-40-125-S	4	4	.125	83	9.1	300	6.8	300	5.2	300
	HWLF-A-100-50-50-125-S	5	5	.125	85	15.5	300	11.8	300	9.1	300
12	HWLF-A-120-40-40-125-S	4	4	.125	87	6.3	300	4.5	300	3.2	300
	HWLF-A-120-50-50-125-S	5	5	.125	89	11.2	300	8.3	300	6.2	300
14	HWLF-A-140-50-50-125-S	5	5	.125	94	8.1	300	5.7	300	5.7	300

### TAPERED FLUTED ROUND

POLE HT. (FT.)	CATALOG NUMBER	SHAFT				80 MPH <sup>1,2</sup>		90 MPH <sup>1,2</sup>		100 MPH <sup>1,2</sup>	
		TOP O.D. (IN)	BASE O.D. (IN)	WALL THK. (IN)	STRUC. WT. <sup>3</sup> (LBS)	MAX LUMINAIRE EPA (SQ FT)	MAX LUMINAIRE WEIGHT (LBS)	MAX LUMINAIRE EPA (SQ FT)	MAX LUMINAIRE WEIGHT (LBS)	MAX LUMINAIRE EPA (SQ FT)	MAX LUMINAIRE WEIGHT (LBS)
8	HWLF-A-080-TF-50-125-T	4.40	5.00	.125	80	21.9	300	17.0	300	13.4	300
10	HWLF-A-100-TF-50-125-T	4.12	5.00	.125	83	15.5	300	11.8	300	9.1	300
12	HWLF-A-120-TF-50-125-T	3.84	5.00	.125	87	11.2	300	8.3	300	6.2	300
14	HWLF-A-140-TF-50-125-T	3.56	5.00	.125	90	8.1	300	5.7	300	4.0	300

<sup>1</sup> Effective Projected Area (EPA) calculations allow for 1.3 Wind Gust Factor. Maximum EPA and weight values are based on top mounted luminaires or arm assembly having a centroid 2'-6" above and 1'-6" eccentric to the pole top at Nominal Mounting Height. Variations from sizes listed above are available upon inquiry. Satisfactory performance of poles is dependent upon the pole being properly attached to a supporting foundation of adequate design. See Williams Outdoor Information Section, page 6, for Load and Dimensional Data specifics.

<sup>2</sup> Wind map provided in Williams Outdoor information section, pole information page 6.

<sup>3</sup> Structure Weight is a nominal value which includes the pole shaft and structural base.

- Pole installations in various parts of the country perform satisfactorily; however, in select locations destructive vibration can occur. H.E. Williams, Inc. is not responsible for vibration induced fatigue damage.
- H.E. Williams, Inc. warrants this product to be free from defects in materials and workmanship. Any defective part returned within one year from the date of delivery of the goods will be repaired or replaced without charge, F.O.B. factory.  
This warranty specifically excludes fatigue or similar phenomena resulting from induced vibration, harmonic oscillation or resonance associated with movement of air currents around the product.  
The above warranties are given in lieu of all other warranties express or implied, including without limitation, the warranty of merchantability and the warranty of suitability for a particular purpose. It is expressly stated that H.E. Williams, Inc. assumes no liability for consequential or liquidated damages arising out of a breach of the sale, including any warranties arising therefrom, and buyer's remedy shall be limited to repair or replacement of defective parts as described above.  
Any action for the breach under a sale including any warranties arising therefrom must be commenced within one year after the cause of action accrues.

**HWLF**

**HISTORIC 16-FLAT FLUTED ALUMINUM POLE WITH SQUARE BASE**

